

Solar PV Grid Tie Inverter

GCI-4.6K[™] DB
inverter

Installation and Operation Manual

Ver 1.0



Ningbo Ginlong Technologies Co., Ltd.

No. 57 Jintong Road, Binhai Industrial Park,
Xiangshan, Ningbo, Zhejiang, 315712, P.R.China

Tel: +86 (0)574 6578 1806

Fax: +86 (0)574 6578 1606

Email: info@ginlong.com

Web: www.ginlong.com

Please record the serial number of your inverter and quote this when you contact us.

© 2011, Ningbo Ginlong Technologies Co., Ltd.

Contents

1. Introduction	3
2. Safety Instructions	4
2.1 Safety Symbols	4
2.2 General Safety Instructions	5
2.3 Intended Use	6
3. Overview	7
3.1 Front Panel Display	7
3.2 LED Status Indicator Lights	7
3.3 Keypad	8
3.4 LCD	8
4. Installation	9
4.1 Select a Location for the Inverter	9
4.2 Mount the Inverter	9
4.3 Electrical Connections	11
4.4 System Installation Requirement	15
4.5 Earthing	15
5. Startup and Stop	16
5.1 Startup the Inverter	16
5.2 Stop the Inverter	16

Contents

6. Operation	17
6.1 Main Menu	17
6.2 Information	17
6.3 Settings	19
6.3.1 Set Time	19
6.3.2 Set Address	19
6.3.3 Clear Energy	20
6.3.4 Restore Settings	20
6.4 Advanced Info.	21
6.4.1 Alarm Message	21
6.4.2 Temperature	21
6.4.3 STD No.	22
6.4.4 Version	22
6.4.5 Communication Data	22
6.5 Advanced Settings	22
6.5.1 Select Standard	23
6.5.2 Grid ON/OFF	24
6.5.3 BT or RS485	24
7. Maintenance	25
8. Trouble Shooting	25
9. Specifications	27

1. Introduction

GCI-4.6K-DB is a transformerless solar grid tie inverter which has excellent MPPT performance to efficiently obtain power from solar panels. It has a wide input voltage range from 100V to 500V and two separately operated MPP Trackers. The maximum input current of GCI-4.6K-DB is 15A dc for each MPPT and maximum output power is 5000W.



2. Safety Instructions

GCI-4.6K-DB has been designed and manufactured to ensure your personal safety. Improper use may result in potential electric shock hazards or burns. This manual contains important instructions that should be followed during installation and maintenance of GCI-4.6K-DB. Please read these instructions carefully before use and keep them for future reference.

2.1 Safety Symbols

Safety symbols used in this manual, which highlight potential safety risks and important safety information, are listed as follows:



WARNING:

WARNING symbol indicates important safety instructions, which if not correctly followed, could result in serious injury or death.



NOTE:

NOTE symbol indicates important safety instructions, which if not correctly followed, could result in damage to or destruction of the inverter.



CAUTION:

CAUTION, RISK OF ELECTRIC SHOCK symbol indicates important safety instructions, which if not correctly followed, could result in electric shock.



CAUTION:

CAUTION, HOT SURFACE symbol indicates safety instructions, which if not correctly followed, could result in burns.

2.Safety Instructions

2.Safety Instructions

2.2 General Safety Instructions



WARNING:

GCI-4.6K-DB is a transformerless inverter. Hence before its operation, it is very important to ensure that the DC input source and the AC output source are electrically isolated. Failure to do so will cause serious damage to the inverter. (CAUTION: AC and DC voltage sources are terminated inside the inverter. The AC circuit and the DC circuit must be isolated from each other before servicing. Each circuit must be individually disconnected before servicing.)



WARNING:

All electrical installations must be done in accordance with the local and National Electrical Code AS/NZS3000.



WARNING:

To reduce the risk of fire, branch circuit overcurrent protective devices are required for circuits connected to GCI-4.6K-DB. The rating of overcurrent device should not exceed 20 amperes.



CAUTION:

Risk of electric shock. Do not remove cover. There are no user serviceable parts inside. Refer servicing to qualified and accredited service technician.



CAUTION:

The PV array (Solar panels) supply a DC voltage when it is exposed to light.



CAUTION:

Risk of electric shock from energy stored in capacitors of GCI-4.6K-DB. Do not remove cover until 5 minutes after disconnecting all sources of supply. Service technician only. Warranty may be void if unauthorized removal of cover.



CAUTION:

GCI-4.6K-DB has a heat sink on its top surface, which helps in cooling the internal components. The heat sink can reach temperatures up to 75°C (167°F). To avoid the risk of burns, do not touch the heat sink when the inverter is operating. To install an inverter on a wooden, painted, or any other combustible surface, a cement sheet is required to be used as a fire retardant material between the wall and the inverter mounting.
Inverter must be installed OUT OF REACH OF CHILDREN.

2.3 Intended Use

The inverter has been constructed according to the applicable safety and technical guidelines. Use the inverter in installations that meet the following specifications ONLY:

1. Permanent installation is required.
2. The inverter must be connected to a separate, grounded AC group, to which no other electrical equipment is connected.
3. The electrical installation must meet all the applicable regulations and standards.
4. The inverter must be installed according to the instructions stated in this manual.
5. The inverter must be installed according to the correct technical specifications.
6. To startup the inverter, the Grid Supply Main Switch (AC) must be switched on before the solar panel DC isolator is switched on. To stop the inverter, the Grid Supply Main Switch (AC) must be switched off before solar panel DC isolator is switched off.
7. The DC input voltage into the GCI-4.6K-DB must NOT exceed 600Vdc.

3. Overview

3. Overview

3.1 Front Panel Display

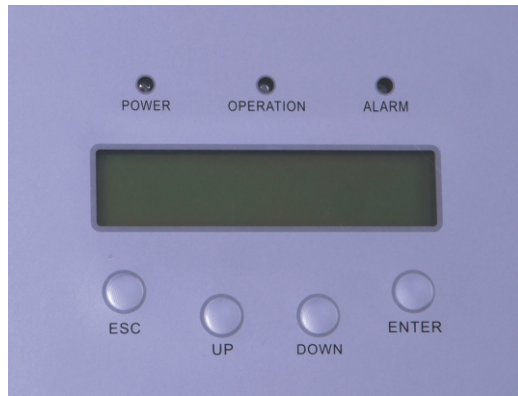

▲ Figure 3.1 Front Panel Display

3.2 LED Status Indicator Lights

There are three LED status indicator lights in the front panel of GCI-4.6K-DB. The left POWER light (red) indicates power status of the inverter. The middle OPERATION light (green) indicates the operation status. The right ALARM light (yellow) indicates the alarm status. Table 3.1 explains their meanings.

Light	Status	Description
● POWER	ON	The inverter is detecting a solar power signal.
	OFF	The inverter has lost a solar power signal.
● OPERATION	ON	The inverter is operating correctly.
	OFF	The inverter has stopped supplying power.
	FLASHING	The inverter is initializing.
● ALARM	ON	Alarm or fault condition is detected. The inverter stores the last 10 messages.
	OFF	The inverter is operating correctly.

▲ Table 3.1 Status Indicator Lights

3.3 Keypad

There are four keys in the front panel of the GCI-4.6K-DB (from left to right): ESC, UP, DOWN and ENTER keys. The keypad is used for:

- Scrolling through the displayed options (the UP and DOWN keys);
- Access to modify the adjustable settings (the ESC and ENTER keys).

3.4 LCD

The two-line Liquid Crystal Display (LCD) is located at the front panel of GCI-4.6K-DB, which shows the following information:

- Inverter operation status and data;
- Service messages for operator;
- Alarm messages and fault indications.

4. Installation

4. Installation

4.1 Select a Location for the Inverter

To select a location for the inverter, the following criteria should be considered:

- The temperature of the inverter heatsink can exceed 75°C. Hence the inverter must be installed at a place where nobody will touch its top.
- The inverter is designed to work in extreme temperatures. The ambient operating temperature range is from -25°C to 60°C.
- A minimum 500mm clearance between the bottom of the inverter and the ground are recommended.



NOTE:

Heat sink must be Out of Reach of Children.

- Visibility of the LED status indicator lights and the LCD located at the front panel of the inverter should be considered.
- Adequate ventilation must be provided if the inverter is to be installed in a confined space.



NOTE:

Nothing should be stored on or placed against the inverter.

4.2 Mount the Inverter

Please use suitable fixings for wall type (e.g. use dynabolts for brick masonry).

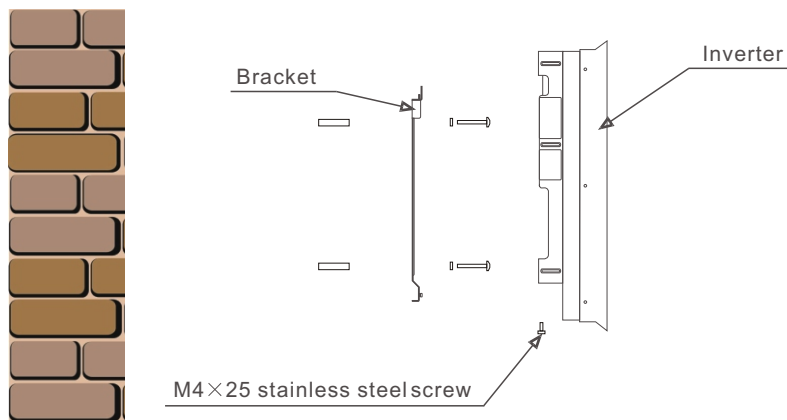

▲ Figure 4.1 Inverter Mounting

Inverter should be mounted in a vertical position as shown in Figure 4.1. The steps to mount the inverter to the wall are given as follows:

1. Locate the wall studs in the desired location and align the wall mount bracket over the studs. Mark the mounting holes. For masonry walls, the mounting holes should be as for a suitable dynabolts type mounting system.
2. MAKE SURE BRACKET IS LEVEL. Ensure mounting holes A, B, C, and D (in Figure 4.2) are aligned with most secure points on wall (e.g. wall studs if clad building materials)



WARNING:

Bracket must be mounted vertically on a vertical wall surface.

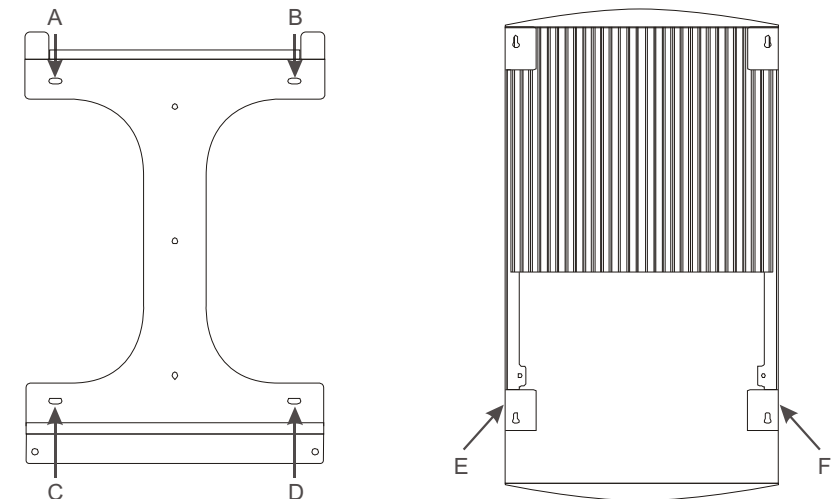

▲ Figure 4.2 Wall Mount Bracket

3. Carefully hang the inverter on the upper part of the wall mount bracket by fitting the hooks into the slot of the bracket. Use M4 x 25 stainless steel screws and washers at holes E and F (in Figure 4.2) to secure the mounting hooks to the rear of the inverter.

4. Installation

4. Installation

4.3 Electrical Connections

GCI-4.6K-DB is designed for electrical connection without removing the cover. The meaning of the symbols located at the bottom of the inverter are listed in Table 4.1. All electrical installations must be in accordance with all local and national electrical codes with reference to include AS/ NZS 3000:2007, AS/ NZS 4777:2005, AS/ NZS 5033:2005. For all AC wiring connections, #10 AWG (maximum), 105°C, copper wires are required to be used.

GRID	Equipment grid wires connect terminal
ANT	Equipment BLUETOOTH antenna connect terminal
COM	Equipment RS485 communication connect terminal
DC1+	The DC input1 positive terminal
DC1-	The DC input1 negative terminal
DC2+	The DC input2 positive terminal
DC2-	The DC input2 negative terminal

▲ Table 4.1 Terminals

GCI-4.6K-DB can transfer the power available to the utility at any input DC voltage that is within the range from 100Vdc to 500Vdc. The maximum input current for each MPPT is 15A dc.

The rated output voltage of GCI-4.6K-DB is 230Vac.

The electrical connection of the inverter must follow the steps listed below:

1. Switch the Solar Supply Main Switch (AC) OFF.
2. Switch the solar panel DC Isolator OFF.
3. Connect GCI-4.6K-DB to the solar panel DC Isolator.
 - a) Make sure the polarity of the output voltage from the solar panel (i.e. The input voltage for GCI-4.6K-DB) matches the “DC+” and “DC-” symbols.
 - b) Attach the positive DC connector (refer to Figure 4.3) to the solar panel output positive terminal. Attach the negative DC connector (refer to Figure 4.4) to the solar panel output negative terminal.



▲ Figure 4.3 DC+ Connector



▲ Figure 4.4 DC- Connector

The steps to assemble the DC connectors are listed as follows:

- i) Disassemble the connector coat (see Figure 4.5).

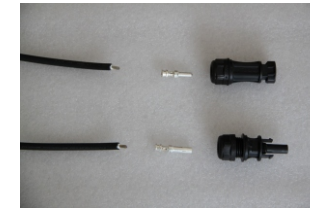

▲ Figure 4.5 Disassemble the Connector Cap

- ii) Insert the wire into the bottom part of the connector coat as shown in Figure 4.6.



▲ Figure 4.6 Insert the Wire into the Connector Cap

- iii) Attach the pin top to the wire as shown in Figure 4.7.



▲ Figure 4.7 Attach the Pin Top to the wire

- iv) Insert the pin to the top part of the connector and screw the top part back on the bottom part of the connector (as shown in Figure 4.8).



▲ Figure 4.8 Connector with Cap Screwed on

4. Installation

v) Then connect the DC± connectors to GCI-4.6K-DB (as shown in Figure 4.9).



▲ Figure 4.9 Connect the DC Connectors to the Inverter

4. Connect GCI-4.6K-DB to the AC grid switch.

Each GCI-4.6K-DB is supplied with an AC grid terminal connector, which is shown in Figure 4.10.



WARNING:

There are “L” “N” “ \perp ” symbols marked inside the connector (see Figure 4.11), the Line wire of grid must be connected to “L” terminal; the Neutral wire of grid must be connected to “N” terminal; the Earth of grid must be connected to “ \perp ” (see Figure 4.12).



▲ Figure 4.10 AC Grid Terminal Connector



▲ Figure 4.11 AC Grid Terminal Connector Inside

4. Installation

The steps to assemble the AC grid terminal connectors are listed as follows:

a) Attach the wires to the grid terminal using screws on the connector (as shown in Figure 4.12).



▲ Figure 4.12 Connect Wires to the Grid Terminal

b) Put the terminal cap on the terminal (as shown in Figure 4.13).



▲ Figure 4.13 Put the Cap on the Terminal

c) Connect the AC grid terminal connector to GCI-4.6K-DB (as shown in Figure 4.14).



▲ Figure 4.14 Connect the Terminal Connector to GCI-4.6K-DB

5. Connect GCI-4.6K-DB to your PC via Rs485 or Bluetooth communication terminal (optional). Please refer to the software application manual.

4. Installation

4.4 System Installation Requirement

Figure 4.15 is a simple guidance for installing a solar system with PV inverter. ADC isolator is required to be installed in the system between the PV panels and the inverter.

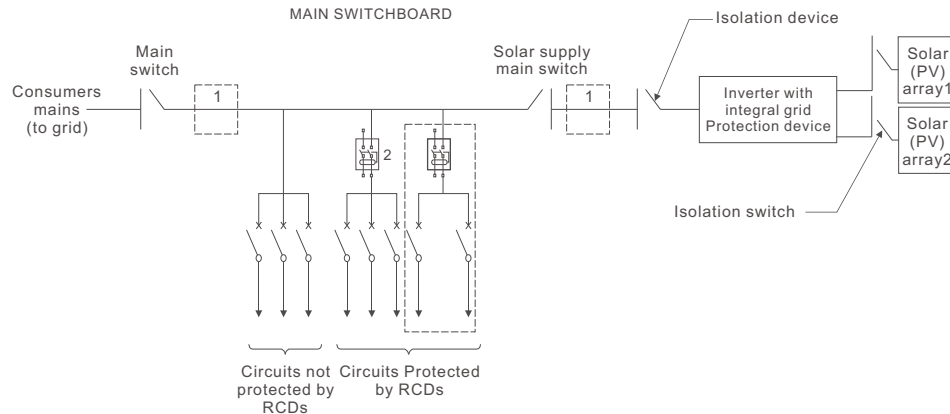

▲ Figure 4.15 Guidance for a Simple Installation of an Inverter Solar PV Energy System



NOTE:

1. The RCD should not be placed between the consumers mains and the solar supply.
2. More than one RCD may be used. Each RCD can protect one or more circuits.

4.5 Earthing

GCI-4.6K-DB must be earthed securely. Inside the inverter, the earth wire is in yellow and green. When the inverter is connected to the grid through the AC grid terminal connector, the earth wire will be connected to the Earth and hence ensure safety.

5. Startup and Stop

5.1 Startup the Inverter

To start up GCI-4.6K-DB, it is important that the following steps are strictly adhered to:

1. Switch the Solar Supply Main Switch (AC) ON first.
2. Switch the solar panel DC Isolator ON. If the solar panels provide normal power supply, GCI-4.6K-DB will turn on (the red light displays and the LCD shows the name of the company and the model name of the inverter).

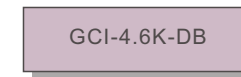

▲ Figure 5.1 Company Name and Model Name on LCD

3. When both the DC side and AC Grid side of GCI-4.6K-DB have power presented, the inverter will prepare to generate. Initially, GCI-4.6K-DB will check both its internal parameters and the parameters of the AC grid to ensure that they are within the acceptable limits. At this time, the green light will flash and the LCD displays the information of INITIALIZING.
4. After 3 mins, GCI-4.6K-DB will generate electricity normally. The green light will remain on and the LCD displays GENERATING.



WARNING:

Do not touch the heat sink when the inverter is operating. Some parts may be hot and cause burns.

5.2 Stop the Inverter

To stop GCI-4.6K-DB, the following steps must be strictly followed:

1. Switch the Solar Supply Main Switch (AC) OFF.
2. Wait 30 seconds. Switch the solar panel DC Isolator OFF. All the LEDs of the inverter will be off in a minute.

6. Operation

During regular operation, the display shows the power and the operation status alternately with each screen lasting for 10 seconds (see Figure 6.1). Screens can also be scrolled manually by pressing the UP and DOWN keys. Pressing the ENTER key gives access to Main Menu.

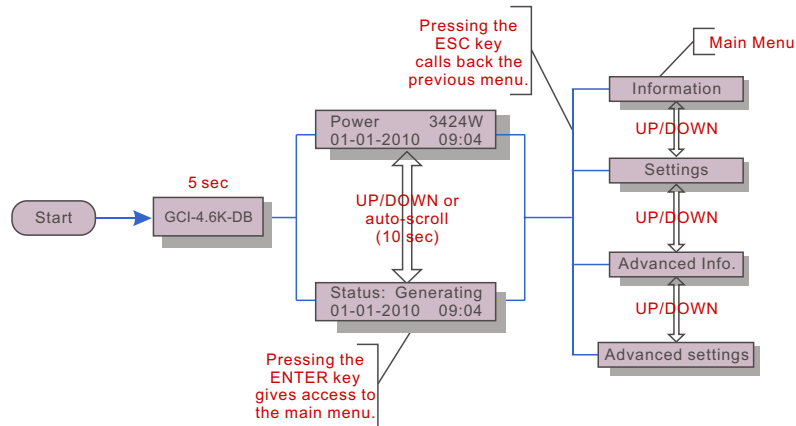

▲ Figure 6.1 Operation Overview

6.1 Main Menu

There are four submenus in the Main Menu (see Figure 6.1):

1. Information
2. Settings
3. Advanced Info
4. Advanced Settings

6.2 Information

The GCI-4.6K-DB main menu provides access to operational data and information. The information is displayed by selecting "Information" from the menu and then by scrolling up or down.

6. Operation

Display	Duration	Description
V_DC1 350.8 I_DC1 5.1A	10 sec	V_DC1: shows input01 voltage value. I_DC1: shows input01 current value.
V_DC2 350.8 I_DC2 5.1A	10 sec	V_DC2: shows input02 voltage value. I_DC2: shows input02 current value.
V_Grid 230.4V I_Grid 8.1A	10 sec	V_Grid: shows grid voltage value. I_Grid: shows grid current value.
Status: generating Power: 1488W	10 sec	Status: shows instant status of GCI-4.6K-DB. Power: shows instant output power value.
Grid Frequency F_Grid 50.06Hz	10 sec	F_Grid: shows instant frequency of grid value.
Total Energy 0258458 kwh	10 sec	Total energy output value (since the last time energy was cleared).
This Month: 0123kwh Last Month: 0123kwh	10 sec	This Month: Total energy output during this month. Last Month: Total energy output of last month.
This day: 02kwh Last day: 01kwh	10 sec	This Day: Total energy output during this Day. Last Day: Total energy output of last Day.

▲ Table 6.1 Information Indicator

Pressing the ESC key returns to the Main Menu. Pressing the ENTER key can lock (Figure 6.2(b)) or unlock (Figure 6.2 (a)) the screen.



(a)



(b)

▲ Figure 6.2 Lock and Unlock the Screen of LCD

6. Operation

6. Operation

6.3 Settings

The following submenus are displayed when the Settings menu is selected:

1. Set Time
2. Set Address
3. Clear Energy
4. Restore Settings

6.3.1 Set Time

This function allows time and date setting. When this function is selected, the LCD will display a screen as shown in Figure 6.3.



NEXT=<ENT> OK=<ESC>
01-01-2010 16:37

▲ Figure 6.3 Set Time

Press the UP/DOWN keys to set time and data. Press the ENTER key to move from one digit to the next (from left to right). Press the ESC key to save the settings and return to the previous menu.

6.3.2 Set Address

This function is used to set the address of an inverter connected to PC for communication purpose. The address number can be assigned from “01” to “99” (see Figure 6.4).

The default address number of GCI-4.6K-DB is “01”.



YES=<ENT> NO=<ESC>
Set Address: 02

▲ Figure 6.4 Set Address

Press the UP/DOWN keys to set the address. Press the ENTER key to save the settings. Press the ESC key to cancel the change and return to the previous menu.

6.3.3 Clear Energy

This function is used to clear energy (total energy, this month energy and last month energy). When Clear Energy is selected, the screen will show the following figure (Figure 6.5).



Are you sure?
YES=<ENT> NO=<ESC>

▲ Figure 6.5 Clear Energy

Press the ENTER key to confirm before executing clearing energy. Press the ESC key to cancel the change and return to the previous menu.

6.3.4 Restore Settings

Do NOT use this function. The inverter is preset to standard AS4777, which must NOT be changed. Access to this function may cause damage to the inverter and may void the warranty.

6.4 Advanced Info - Technicians Only



NOTE:

Access to this area is for fully qualified and accredited technicians only. Unauthorized access to these areas may void the warranty.

Select Advanced Info. from the Main Menu to display a screen to access the following information

1. Alarm Message
2. Temperature
3. STD NO.
4. Version
5. Communication Data

Screens can be scrolled manually by pressing the UP/DOWN keys. Pressing the ENTER key gives access to submenu. Press the ESC key to return to the Main Menu.

6.4.1 Alarm Message

The display shows 10 latest alarm messages (see Figure 6.9). Screens can be scrolled manually by pressing the UP/ DOWN keys. Press the ESC key to return to the previous menu.

```
Alarm0: OV-G-V
Time: 27-11 Data: 7171
```

▲ Figure 6.9 Alarm Message

6.4.2 Temperature

The screen shows the power module temperature of GCI-4.6K-DB (see Figure 6.10).

```
Temperature
046.6
```

▲ Figure 6.10 Temperature of the Inverter

6.4.3 STD NO.

The screen shows the reference standard of GCI-4.6K-DB (see Figure 6.11).

```
Standard: AS4777
```

▲ Figure 6.11 Standard of the Inverter

6.4.4 Version

The screen shows the model version and the software version of GCI-4.6K-DB (see Figure 6.12).

```
Model: 88
Software Version: D201
```

▲ Figure 6.12 Model Version and Software Version

6.4.5 Communication Data

The screen shows the internal data of GCI-4.6K-DB (see Figure 6.13), which is for service technicians only.

```
01-05: 01 25 E4 9D AA
06-10: C2 B5 E4 9D 55
```

▲ Figure 6.13 Communication Data

6.5 Advanced Settings - Technicians Only



NOTE:

Access to this area is for fully qualified and accredited technicians only. Unauthorized access to these areas may void the warranty.

Select Advanced Settings from the Main Menu to access the following options:

1. Select Standard
2. Grid ON/OFF
3. BT or RS485

6.5.1 Select Standard

This function is used to select reference standard of grid (see Figure 6.14).



▲ Figure 6.14



NOTE:

This function exists for technician use only.



NOTE:

You must set Grid OFF first (refer to Section 6.5.2) to use this function.



NOTE:

Your inverter must be set to AS4777 only.

Press the UP/DOWN keys to select the standard (AS4777, VDE0126, UL1741, G83, User-Def). Press the ENTER key to confirm the setting. Press the ESC key to cancel the change and return to the previous menu.

Selecting the User-Def menu will access to the following submenu (see Figure 6.15):

OV-V: 240---270V

UN-V: 180---210V

OV-G-F: 50.3---52.0Hz(60.3—62.0Hz)

UN-G-F: 47.0---49.5Hz(57.0—59.5Hz)



NOTE:

The initial values of the User-Def standard are some reference values. They are not indicating the values of the standard you are currently using.

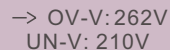

▲ Figure 6.15

Press the UP/DOWN keys to scroll through items. Press the ENTER key to edit the highlighted item. Press the UP/DOWN keys again to change the setting. Press the ENTER key to save the setting. Press the ESC key to cancel the change and return to the previous menu.



NOTE:

You must set Grid ON (refer to Section 6.5.2) before the new standard can be used.

6.5.2 Grid ON/OFF

This function is used to start or stop the generation of GCI-4.6K-DB (see Figure 6.16).



▲ Figure 6.16 Set Grid ON/OFF

Screens can be scrolled manually by pressing the UP/DOWN keys. Press the ENTER key to save the setting. Press the ESC key to return to the previous menu.

6.5.3 BT or RS485

This function is used to select the BLUETOOTH communication mode or RS485 communication mode.



▲ Figure 6.17 BT or RS485

Screens can be scrolled manually by pressing the UP/DOWN keys. Press the ENTER key to save the setting. Press the ESC key to return to the previous menu.

7. Maintenance

GCI-4.6K-DB does not require any regular maintenance from the user. However, impurities such as dirt may affect the heat accumulation of the inverter and hence its performance. The dirt on the inverter can be cleaned with a soft brush.



CAUTION:

Do not touch the heat sink when the inverter is operating. Some parts may be hot and cause burns. Turn OFF your inverter (refer to Section 5.2) and let it cool down before you do any maintenance or cleaning of inverter.

The LCD and the LED status indicator lights can be cleaned with a damp cloth if they are too dirty to be read.



NOTE:

Never use any solvents, abrasives or corrosive materials to clean the inverter.

Trouble Shooting

GCI-4.6K-DB is designed in accordance with the standards of grid-tied operation, safety requirements and electromagnetic compatibility. Before being delivered to the customer, GCI-4.6K-DB has been subjected to several tests to ensure its optimal operation, reliable performance and good durability.

If an operational failure occurs, the LCD screen will display an alarm message. In this case, the inverter stops feeding into the grid. The possible failure scenarios and their corresponding alarm messages are listed in Table 8.1:

8. Trouble Shooting

Alarm Message	Failure Scenario
OV-G-V	Over grid voltage
UN-G-V	Under grid voltage
OV-G-F	Over grid frequency
UN-G-F	Under grid frequency
G-IMP	Grid impedance high
NO-Grid	No grid
OV-DC	Over DC voltage
OV-BUS	Over DC bus voltage
UN-BUS	Under DC bus voltage
SHORT-PRO	Short circuit fault
INI-PRO	System initial fault
TEM-PRO	Over Temperature
GROUND-PRO	Ground fault

▲ Table 8.1 Failure Scenarios



NOTE:

If your GCI-4.6K-DB gives any alarm message listed in Table 8.1, turn off your inverter (refer to Section 5.2 to stop your inverter) and wait for 30 minutes before restarting it (refer to Section 5.1 to start your inverter). If the failure has not been cleared, contact your local distributor or the service centre. Please have the following information ready with you before you contact us.

1. Serial number of GCI-4.6K-DB;
2. The distributor/dealer of GCI-4.6K-DB (if available);
3. Installation date.
4. The description of problem (i.e. the alarm message displayed on the LCD and the status of the LED status indicator lights. Other readings obtained from the Information submenu (refer to Section 6.2) will also be helpful.);
5. System design for the solar PV array configuration (e.g. number of panels, capacity of panels, number of strings, etc.);
6. Your contact details.

9. Specifications

The DC Maxvoltage	600Vdc
The DC MPPT range	100V~500Vdc
The number of MPPT	2
The rating maxDC input current(each MPPT)	15Adc
The rating grid voltage	230Vac
The grid voltage range	205~270Vac (adjustable)
Operation phase	single
Rating grid output current	20.0Aac
Rating output power	4.6KW
Grid current THD	Total THd<4%,
The DC injection current	<50mA
Output power factor	>0.99
Grid frequency range	47.0~52.0Hz (adjustable)
Max efficiency	>97%
Design lifetime	>20 years
Operation environment temperature	-25~60°C

▲ Table9.1 Specifications